

性能特点

- 1.体积小、轻巧
- 2.耐横向负载能力强
- 3.耐扭矩能力强
- 4.不回转精度高
- 5.导向杆的轴承可选择滑动轴承或球轴承
- 6.安装方便
- 7.二面接管位置可供选择



订购码

MGPM		32	x	50	-	MT
轴承种类	缸径	行程		磁性开关的型号		
M: 滑动轴承	12 16			D-A93		
L: 球轴承	20 25			*标准线长1M		
	32 40			特殊另订购		
	50 63					
	80 100					

订货举例:

- 1)所需缸径: 12, 行程: 50, 滑动轴承
正确型号: MGPM12-50
- 2)所需缸径: 40, 行程: 100, 球轴承
带2个磁性开关, 引线长0.5m
正确型号: MGPL40-100-MT2

规格

缸径(mm)	12	16	20	25	32	40	50	63	80	100
使用液体	空气									
动作方式	双作用									
耐压试验压力	1.5MPa (15.3kgf/cm ²)									
最高使用压力	1.0MPa (10.2kgf/cm ²)									
最低使用压力	0.12MPa (1.2kgf/cm ²)									
环境和流体温度	5~+60°C									
活塞速度	50~500mm/s								50~400mm/s	
缓冲	橡胶缓冲									
行程公差	+1.5mm 0									
*给油	不需要									
轴承	滑动轴承/球轴承									
活塞杆不回转精度	滑动轴承	±0.08°	±0.07°	±0.06°	±0.05°	±0.04°				
	球轴承	±0.10°	±0.09°	±0.08°	±0.06°	±0.05°				
接管口径Rc(PT)	M5x0.8			1/8 "		1/4 "		3/8 "		

*如需给油,请用透平油1号ISOVG32.

行程

缸径(mm)	标准行程*(mm)	**磁性开关型号 (轨道安装)
12, 16	10, 20, 30, 40, 50, 75, 100	D-Z73L D-Z76L D-Z80L D-Y59AL D-Y59BL
20, 25	20, 30, 40, 50, 75, 100, 125, 175, 200	
32, 40, 50, 63, 80, 100	20, 50, 75, 100, 125, 150, 175, 200	

*中间行程(5, 10, 20, 30, 35.....)是加5, 10, 15, 20mm厚的垫板, 例如: MGPM50-10是加15mm厚的垫板在MGPM50-25之内

**磁性开关规格及特性可参阅磁性开关系列。引线长度表示记号: 无记号-0.5m, L-3m, 例: D-Y59AL D-Y59AL

气缸类

计算式
SI
SI附
SIB
SQ
DNT
SC / SU
SCT
SC附
SL
DN
DSN
DN/DSN附
MA
MAC
MA/MAC附
MAL
MALC
MAL/MALC附
SDA
CQ2
TCQ2
ADN
TADN
PPRM
ZX
MHL2
气手指
MXH/MXQ
CJP
CJ2
CDU
TN
CXS

MGP

MSQ

MGP新薄型 带导杆气缸 (Ø20~Ø100)



- 气缸类
- 计算式
- SI
- SI附
- SIB
- SQ
- DNT
- SC / SU
- SCT
- SC附
- SL
- DN
- DSN
- DN/DSN附
- MA
- MAC
- MA/MAC附
- MAL
- MALC
- MAL/MAL附
- SDA
- CQ2
- TCQ2
- ADN
- TADN
- PPRM
- ZX
- MHL2
- 气手指
- MXH/MXQ
- CJP
- CJ2
- CDU
- TN
- CXS
- MGP
- MSQ

负载及扭矩

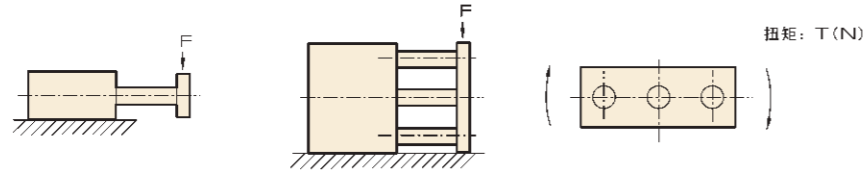

缸径(mm)	系列	最大横向负载 F (N)											
		行程(mm)											
		10	20	25	30	40	50	75	100	125	150	175	200
12	MGPM	24	19	-	17	14	13	26	22	-	-	-	-
	MGPL	37	27	-	22	35	30	23	18	-	-	-	-
16	MGPM	38	31	-	27	23	21	37	32	-	-	-	-
	MGPL	54	40	-	32	54	47	35	28	-	-	-	-
20	MGPM	-	49	-	43	38	35	87	75	66	59	54	49
	MGPL	-	58	-	48	101	90	70	58	62	54	48	43
25	MGPM	-	69	-	60	54	49	116	100	88	79	71	65
	MGPL	-	82	-	68	132	118	93	77	80	70	62	55
32	MGPM	-	-	203	-	-	164	182	159	142	127	116	106
	MGPL	-	-	113	-	-	78	130	107	130	114	101	90
40	MGPM	-	-	203	-	-	164	182	159	142	127	116	106
	MGPL	-	-	113	-	-	78	129	106	130	114	101	90
50	MGPM	-	-	296	-	-	245	273	241	216	195	179	164
	MGPL	-	-	120	-	-	83	178	148	148	129	114	102
63	MGPM	-	-	296	-	-	245	273	241	216	195	179	164
	MGPL	-	-	117	-	-	81	176	145	145	126	111	99
80	MGPM	-	-	352	-	-	297	368	329	298	272	251	232
	MGPL	-	-	125	-	-	99	281	240	208	184	163	147
100	MGPM	-	-	515	-	-	445	498	450	410	377	349	325
	MGPL	-	-	138	-	-	108	395	340	297	263	235	211

缸径(mm)	系列	最大扭矩 T (N*m)											
		行程(mm)											
		10	20	25	30	40	50	75	100	125	150	175	200
12	MGPM	0.39	0.32	-	0.27	0.24	0.21	0.43	0.36	-	-	-	-
	MGPL	0.78	0.66	-	0.57	0.93	0.85	0.69	0.58	-	-	-	-
16	MGPM	0.69	0.58	-	0.49	0.43	0.38	0.69	0.58	-	-	-	-
	MGPL	1.23	1.06	-	0.92	1.53	1.40	1.16	0.99	-	-	-	-
20	MGPM	-	1.05	-	0.93	0.83	0.75	1.88	1.63	1.44	1.28	1.16	1.06
	MGPL	-	1.70	-	1.52	3.06	2.87	2.47	2.17	2.38	2.16	1.98	1.82
25	MGPM	-	1.76	-	1.55	1.38	1.25	2.96	2.57	2.26	2.02	1.83	1.67
	MGPL	-	2.80	-	2.53	4.67	4.39	3.81	3.36	3.65	3.31	3.02	2.78
32	MGPM	-	-	6.35	-	-	5.13	5.69	4.97	4.42	3.98	3.61	3.31
	MGPL	-	-	4.76	-	-	3.86	6.53	5.75	7.10	6.46	5.92	5.47
40	MGPM	-	-	7.00	-	-	5.66	6.27	5.48	4.87	4.38	3.98	3.65
	MGPL	-	-	5.24	-	-	4.25	7.19	6.33	7.81	7.11	6.52	6.02
50	MGPM	-	-	13.0	-	-	10.8	12.0	10.6	9.50	8.60	7.86	7.24
	MGPL	-	-	7.02	-	-	5.76	12.3	10.9	11.2	10.2	9.40	8.69
63	MGPM	-	-	14.7	-	-	12.1	13.5	12.0	10.7	9.69	8.86	8.16
	MGPL	-	-	77.7	-	-	6.35	13.7	12.2	12.5	11.4	10.5	9.65
80	MGPM	-	-	22.0	-	-	18.6	22.9	20.5	18.6	17.0	15.6	14.5
	MGPL	-	-	10.3	-	-	9.35	24.8	22.7	20.9	19.4	18.0	16.9
100	MGPM	-	-	38.8	-	-	33.5	37.5	33.8	30.9	28.4	26.2	24.4
	MGPL	-	-	13.6	-	-	12.2	41.1	37.9	35.1	32.7	30.5	28.6

ISO9001:2015 CE

MGP新薄型 带导杆气缸 (Ø20~Ø100)

外形尺寸

MGP
Ø12~Ø25

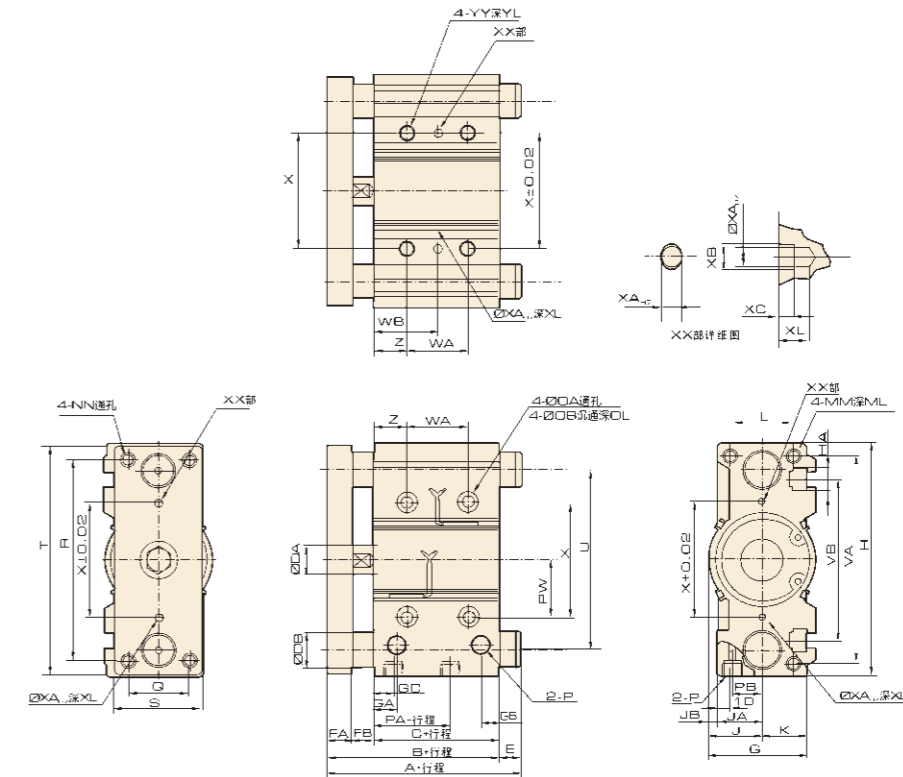

尺寸表

MGPM, MGPL尺寸表 (Ø12~Ø25)

缸径 (mm)	标准行程	B	C	DA	FA	FB	G	GA	GB	H	HA	J	K	L	MM	ML	NN	OA	OB	OL	P	PA	PB	PW	Q
12	10,20,30,40,	42	29	6	8	5	26	11	7.5	58	M4	13	13	18	M4x0.7	10	M4x0.7	4.3	8	4.5	M5x0.8	13	8	18	14
	50,75,100	46	33	8	8	5	30	11	8	64	M4	15	15	22	M5x0.8	12	M5x0.8	4.3	8	4.5	M5x0.8	15	10	19	16
16	20,30,40,50,75,100,	53	37	10	10	6	36	10.5	8.5	83	M5	18	18	24	M5x0.8	13	M5x0.8	5.6	9.5	5.5	Rc1/8	12.5	10.5	25	18
		125,150,175,200	53.5	37.5	12	10	6	42	11.5	9	93	M5	21	21	30	M6x1.0	15	M6x1.0	5.6	9.5	5.5	Rc1/8	12.5	13.5	28.5

缸径 (mm)	标准行程	WA											WB										
		R	S	T	U	VA	VB	30st以下	40st至100st	125st或以上	30st以下	40st至100st	125st或以上	X	XA	XB	XC	XL	YY	YL	Z		
12	10,20,30,40,	48	22	56	41	50	37	20	40	-	15	25	-	23	3	3.5	3	6	M5x0.8	10	5		
	50,75,100	54	25	62	46	56	38	24	44	-	17	27	-	24	3	3.5	3	6	M5x0.8	10	5		
16	20,30,40,50,75,	70	30	81	54	72	44	24	44	120	29	39	77	28	3	3.5	3	6	M6x1.0	12	17		
		100,125,150,175,200	78	38	91	64	82	50	24	44	120	29	39	77	34	4	4.5	3	6	M6x1.0	12	17	

MGPM (滑动轴承)

缸径 (mm)	A		DB	E	
	50st以下	50st以上		50st以下	50st以上
12	42	60.5	8	0	18.5
16	46	64.5	10	0	18.5
20	53	84.5	12	0	31.5
25	53.5	85	16	0	31.5

MGPL (球轴承)

缸径 (mm)	A			DB	E		
	30st以下	30st至100st	100st或以上		30st以下	30st至100st	100st或以上
12	43	55	85	6	1	13	43
16	49	65	95	8	3	19	49
20	63	80	104	10	10	27	51
25	69.5	80.5	104.5	13	16	32	51

- 气缸类
- 计算式
- SI
- SI附
- SIB
- SQ
- DNT
- SC / SU
- SCT
- SC附
- SL
- DN
- DSN
- DN/DSN附
- MA
- MAC
- MA/MAC附
- MAL
- MALC
- MAL/MAL附
- SDA
- CQ2
- TCQ2
- ADN
- TADN
- PPRM
- ZX
- MHL2
- 气手指
- MXH/MXQ
- CJP
- CJ2
- CDU
- TN
- CXS
- MGP
- MSQ

MGP新薄型 带导杆气缸 (Ø20~Ø100)



外形尺寸

MGP Ø32~Ø63

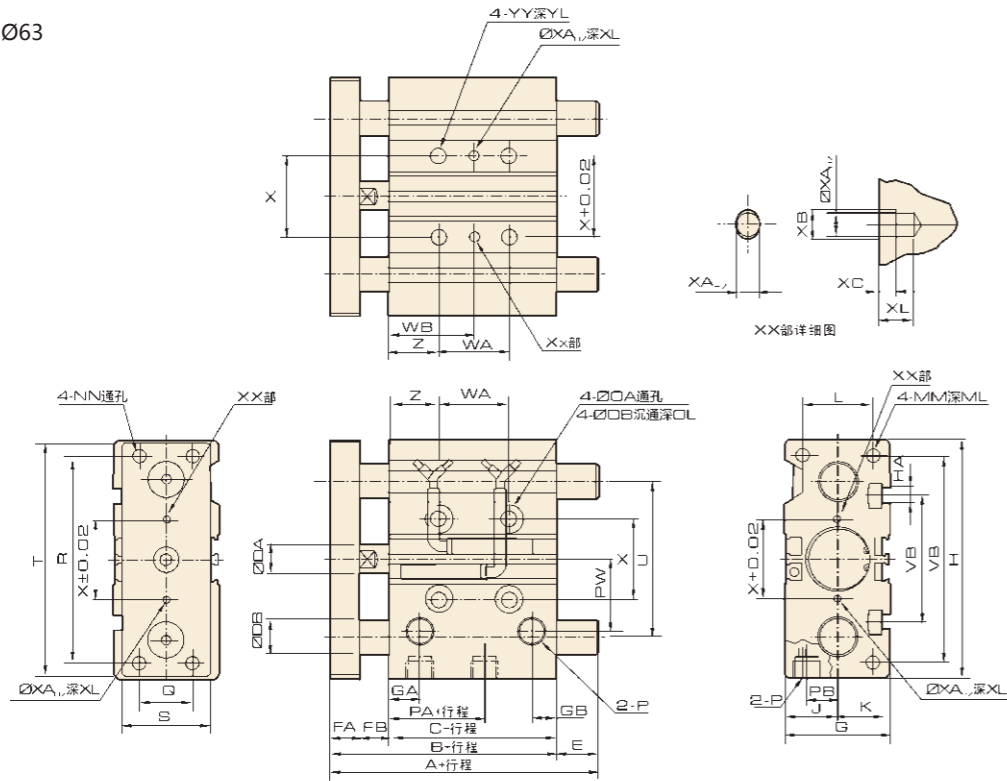

尺寸表

MGPM, MGPL尺寸表 (Ø32~Ø63)

缸径 (mm)	标准行程	B	C	DA	FA	FB	G	GA	GB	GC	H	HA	J	K	L	MM	ML	NN	OA	OB	OL	P	PA	PB	PW	Q
32	25,50,75, 100,125,150, 175,200	59.5	37.5	16	12	10	48	12.5	112	9	112	M6	24	24	34	M8x1.25	20	M8x1.25	6.6	11	7.5	Rc1/8	7	15	34	30
40		66	44	16	12	10	54	14	120	10	120	M6	27	27	40	M8x1.25	20	M8x1.25	6.6	11	7.5	Rc1/8	13	18	38	30
50		72	44	20	16	12	64	12	148	11	148	M8	32	32	46	M10x1.5	22	M10x1.5	8.6	14	9	Rc1/4	9	21.5	47	40
63		77	49	20	16	12	78	16.5	162	13.5	162	M10	39	39	58	M10x1.5	22	M10x1.5	8.6	14	9	Rc1/4	14	28	55	50

缸径 (mm)	标准行程	R	S	T	U	VA	VB	WA			WB			X	XA	XB	XC	XL	YY	YL	Z
								25st	50,75,100st	100st以上	25st	50,75,100st	100st以上								
32	25,50,75, 100,125, 150,175,200	96	44	110	78	98	63	24	48	124	33	45	83	42	4	4.5	3	6	M8x1.25	16	21
40		104	44	118	86	106	72	24	48	124	34	46	84	50	4	4.5	3	6	M8x1.25	16	22
50		130	60	146	110	130	92	24	48	124	36	48	86	66	5	6	4	8	M10x1.5	20	24
63		130	70	158	124	142	110	28	52	128	38	50	88	80	5	6	4	8	M10x1.5	20	24

MGPM (滑动轴承)

缸径 (mm)	A		DB	E	
	25,50st	50st以上		25,50st以下	50st以上
32	97	102	20	37.5	42.5
40	97	102	20	31	36
50	106.5	118	25	34.5	46
63	106.5	118	25	29.5	41

MGPL (球轴承)

缸径 (mm)	A			DB	E		
	50st	75,100st	100st以上		50st	75,100st	100st以上
32	81	98	118	16	21.5	38.5	58.5
40	81	98	118	16	15	32	52
50	93	114	134	20	21	42	62
63	93	114	134	20	16	37	57

ISO9001:2015 CE

MGP新薄型 带导杆气缸 (Ø20~Ø100)

外形尺寸

MGP Ø80~Ø100

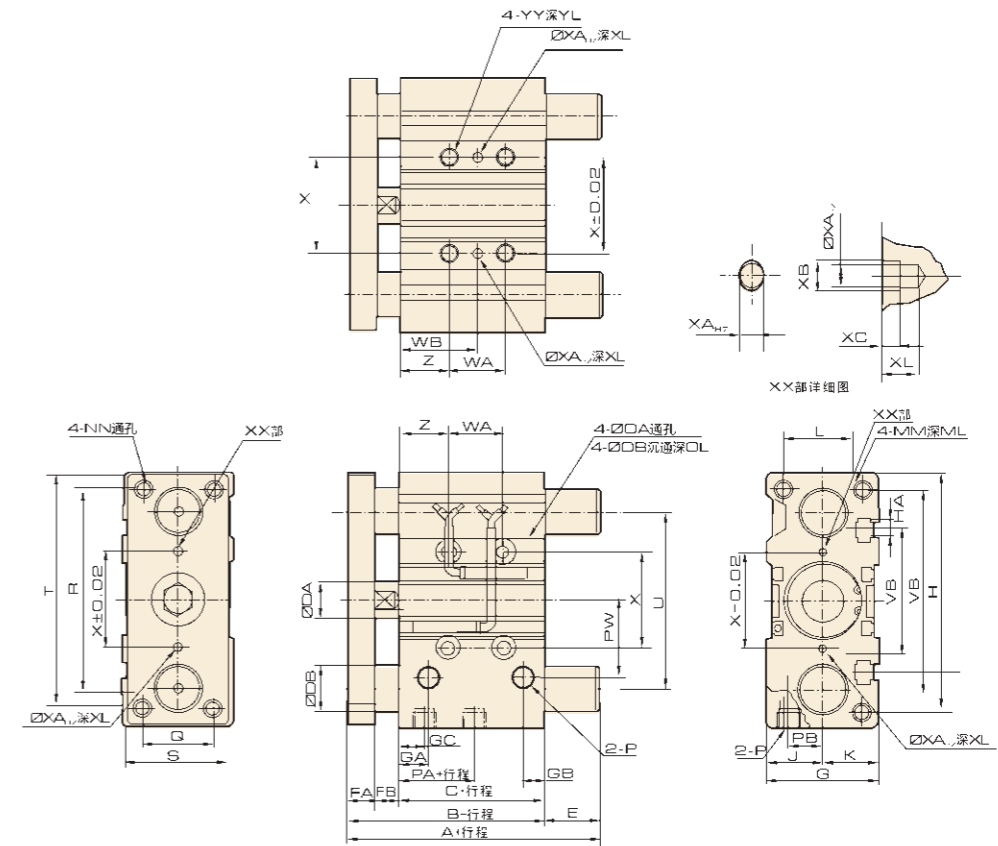

尺寸表

MGPM, MGPL尺寸表 (Ø80~Ø100)

缸径 (mm)	标准行程	B	C	DA	FA	FB	G	GA	GB	GC	H	HA	J	JA	JB	K	L	MM	ML	NN	OA	OB	OL	P	PA	PB	PW	Q
80	25,50,75, 100,125,150, 175,200	96.5	56.5	25	22	18	91.5	19	15.5	14.5	202	M12	45.5	38	7.5	46	54	M12x1.75	30	M12x1.75	10.6	17.5	8	Rc3/8	14.5	25.5	74	52
100		116	66	30	25	25	111.5	23	19	18	240	M14	55.5	45	10.5	56	62	M14x2.0	32	M14x2.0	12.5	20	8	Rc3/8	17.5	32.5	89	64

缸径 (mm)	标准行程	R	S	T	U	VA	VB	WA			WB			X	XA	XB	XC	XL	YY	YL	Z
								25st	50,75,100st	100st以上	25st	50,75,100st	100st以上								
80	25,50,75, 100,125,150, 175,200	174	75	198	156	180	140	28	52	128	42	54	92	100	6	7	5	10	M12x1.75	24	28
100		210	90	236	188	210	166	48	72	148	35	47	85	124	6	7	5	10	M14x2.0	28	11

MGPM (滑动轴承)

缸径 (mm)	A		DB	E	
	25,50st	50st以上		25,50st以下	50st以上
80	115	142	30	18.5	45.5
100	137	162	36	21	46

MGPL (球轴承)

缸径 (mm)	A			DB	E		
	25,50st	75,100st	100st以上		25,50st	75,100st	100st以上
80	109.5	130	160	25	13	33.5	63.5
100	121	147	180	30	5	31	64